

(19)



Europäisches Patentamt
European Patent Office
Office européen des brevets



(11) EP 0 713 953 B1

(12)

EUROPEAN PATENT SPECIFICATION

(45) Date of publication and mention of the grant of the patent:
02.10.2002 Bulletin 2002/40

(51) Int Cl.7: E21B 43/04, E21B 43/10,
E21B 23/00, E21B 43/116,
E21B 7/06

(21) Application number: 95118243.5

(22) Date of filing: 20.11.1995

(54) Method of drilling and completing wells

Verfahren zum Bohren und Komplettieren von Bohrlöchern
Méthode de forage et d'achèvement des puits

(84) Designated Contracting States:
DE FR GB NL

(30) Priority: 22.11.1994 US 343746

(43) Date of publication of application:
29.05.1996 Bulletin 1996/22

(73) Proprietor: BAKER HUGHES INCORPORATED
Houston, Texas 77027 (US)

(72) Inventors:
• Donovan, Joseph F.
Spring, Texas 77389 (US)

• Johnson, Michael H.
Spring, Texas 77389 (US)
• Turick, Daniel J.
Spring, Texas 77379 (US)

(74) Representative: Finck, Dieter, Dr.Ing. et al
v. FÜner Ebbinghaus Finck Hano
Mariahilfplatz 2 - 3
81541 München (DE)

(56) References cited:
EP-A- 0 462 618 US-A- 4 526 233
US-A- 5 044 437 US-A- 5 174 379
US-A- 5 293 940

Note: Within nine months from the publication of the mention of the grant of the European patent, any person may give notice to the European Patent Office of opposition to the European patent granted. Notice of opposition shall be filed in a written reasoned statement. It shall not be deemed to have been filed until the opposition fee has been paid. (Art. 99(1) European Patent Convention).

Description

[0001] The present invention relates to drilling and completing of wells. In particular, but not by way of limitation, the invention relates to drilling and completing of hydrocarbon wells.

[0002] In order to recover hydrocarbons, a well is drilled into the ground until a hydrocarbon reservoir is encountered. In the earlier days of oil and gas exploration, most well sites were located on shore, and the wells that were drilled were primarily vertical. As the search for larger hydrocarbon reservoirs continues, the exploration is now focusing on offshore locations and remote land sites. Further, many wells are being drilled and completed as highly deviated and horizontal wells for economical and logistical reasons.

[0003] A method and device for perforating a wall of a well by use of a tool such as an explosive gun is known from U.S. 5,044,437. Said method includes the use of an intervention set. This set has a perforating tool associated with a measuring box such as a logging sonde and temperature and pressure sensors which is taken down into the well. The set is suspended by a linking cable on a support frame which can be locked inside and at the base of a tubing. The tubing is taken down to the intervention area and blocked by a packer. The support frame and the set are displaced by a control cable lowered down from the surface and the best places for carrying out shootings or perforations in the well are determined through measurements made by the measuring box. Sensors contained in the box allow an operator to check the results. After the intervention, the perforating tool, for example, an explosive gun, is left in the well and the support frame and the box are taken up in order to clear the inside of the tubing.

[0004] In offshore waters, one type of installation includes use of a fixed platform wherein the legs of the platform are rigid and embedded into the sea floor. The fixed platform has been a very popular type of structure; however, as the search for reserves continues, oil and gas companies find themselves searching in offshore locations where the water depths may be as deep as 1.829m (6,000').

[0005] As regards land locations, the exploration, drilling and production are now taking place in remote locations that may include arctic regions, desert regions, or even the rain forest of Latin America. Regardless of the inland or offshore location of these rigs, the remote nature of their location and the necessary ancillary equipment and personnel that must follow, the rental rates for these rigs are very significant.

[0006] In offshore waters, traditional fixed platforms can not be placed in depths generally greater than 91.4m (300'). Therefore, tension leg platforms, drilling ships or semi-submersible drilling vessels are being used to drill these deep water wells. Typically, this involves the drilling rig being placed on the ship or floater. A sub sea Blow Out Preventor stack (BOP) is then

placed on the ocean floor. A riser is then connected from the sub-sea BOP to the drill floor. The bore hole can then be drilled.

[0007] Once the well has been drilled and a hydrocarbon reservoir has been encountered, the well is ready to be completed. Many sub-sea wells are completed as single satellite wells producing to a nearby platform. They are a means of producing field extremities that cannot be reached by directional drilling from an existing platform and where the economics do not justify the installation of one or more additional platforms. Some multi-well templates and piping manifolds have been installed that go beyond the satellite well concept.

[0008] While the governments have recognized the importance and the necessity of drilling and completing wells in remote locations, significant regulations exist for each phase of the drilling, completing, and producing operation. Thus, when a certain size drill string is substituted for a second size, or alternatively, for production tubing, operators will require the changing of the BOP ram members so that control of the well bore is always maintained. This is a crucial concern because control of the well bore is essential at all times.

[0009] When the operator is converting from the drilling phase to the completion phase, the BOP stack must be changed out to accommodate the different outer diameter sized work string—from drill pipe to a production string. Furthermore, during the actual completion phase, the production tubing must be manipulated in order to perform the necessary functions such as perforating, circulating, gravel packing and testing. According to established safety procedures mandated by operator rules and government regulations, it is necessary to change out the BOP rams during certain phases. The changing out of BOP rams can be a costly and time consuming practice. Day rates for drill ships and semi-submersible ships can be quite expensive, and during the procedure for changing out the rams, no other substantive operations can be accomplished.

[0010] In a typical offshore location, wherein the drilling rig is either a jack-up vessel or placed upon a fixed platform, the BOP is normally situated on the vessel or platform itself. Nevertheless, because of safety considerations and government regulations, the control of the well bore from blow-out is always of primary concern. Therefore, safety of the installation along with economically performing the operation has always been a need.

[0011] In order to minimize cost, several techniques have been employed with varying degrees of success. One technique has been to drill and case the well, and then immobilize the drilling rig. A replacement rig is then utilized to complete the well. The replacement rig may vary from a snubbing unit, coiled tubing unit, work over rig using smaller inner diameter pipe, and in some cases wire line. Thus, rather than completing the well with the more expensive rig, a less expensive rig is utilized. Therefore, there is a need to provide for a more cost effective method and means for drilling and completing

wells in the exotic locations of the world.

[0012] According to the invention this object is achieved by a method according to claim 1 and by an apparatus according to claim 3.

[0013] An advantageous and preferred development of the method according to the invention is subject matter of claim 2. Preferred and advantageous embodiments of the apparatus according to the invention are subject matter of claims 4 to 11.

[0014] Embodiments of the invention will now be described herein below with respect to the accompanying drawings in which:

Figure 1 is a semi-submersible drilling platform showing the drilling rig with casing and the target reservoir.

Figures 2A-2B are a cut through section of a bottom hole assembly being positioned in a well.

Figures 3A-3B are a cut through section of the bottom hole assembly of Figs. 2A-2B after the perforating means have been released.

Figures 4A-4B are a cut through section of the bottom hole assembly of Figs. 3A-3B having been engaged with gravel packing means on a coil tubing string.

Figures 5A-5B are a cut through section of a bottom hole assembly containing drilling means being positioned in a well.

Figures 6A-6B are a cut through section of the bottom hole assembly of Figs. 5A-5B drilling a bore hole.

Figures 7A-7B are a cut through section of the bottom hole assembly of Figs. 6A-6B after the drilling means has been released.

Figures 8A-8B are a cut through section of the bottom hole assembly of Figs. 7A-7B having been engaged with gravel packing means on a coil tubing string.

[0015] Fig. 1 depicts a semi-submersible drilling vessel 2 that has contained thereon a drilling rig 4. In order to control the pressures encountered from the subterranean reservoirs, a sub-sea Blow-Out Preventor stack 8 is positioned on the ocean floor 10, with a riser 12 linking the sub-sea BOP stack 8 and the drilling rig. Extending into the earth from the sub-sea stack 8 will be the well casings, including the conductor, surface, and intermediate 14, 16, and 18, respectively. A stationary string 20 is positioned within the riser 12 and casing string 18.

[0016] As is well understood by those of ordinary skill in the art, the casing strings will intersect various sub-

terranean reservoirs 22, some of which may contain hydrocarbons. As is shown in Fig. 1, a target reservoir 24 has yet to be drilled through.

[0017] Referring now to Figs. 2A-2B, a bottom hole assembly 30 is positioned within a casing string 32. Within the casing string 32 will be a stationary string 34 with an internal diameter 36 and an outer diameter 38, which in this illustration may be a production string, but it should be understood that the string may be other types of conduit including drill pipe. The stationary string will have included a nipple profile means 40 for the setting of various devices, with the nipple means 40 having an internal profile 42.

[0018] The string 34 may also contain packer means 44 for sealingly engaging the inner diameter of the casing 32 so that when packer means 44 is set, an annulus between the string 34 and casing 32 is formed. The packer means 44 may be of the hydraulic and mechanical type and are commercially available from Baker Hughes Incorporated under the product name "SC" style packers. An upper annulus 46 would be formed from the packer means 44 to the surface, and a lower annulus 48 would be formed below the packer means 44. The string 34 may consist of a gravel pack extension section means 50 for the placement of a gravel slurry through the ports 52 in the lower annulus 48, as will be more fully explained later in the application. The gravel pack extension means 50 is commercially available from Baker Hughes Incorporated under the trade name "S-1" Gravel Pack Extension.

[0019] The string 34 may also contain a mechanical release profile means 54, which will have an internal profile 56, for the placement of a mechanical setting & release tool, as will be described hereafter.

[0020] The bottom hole assembly 30 will be attached to a release mechanism 58 that will contain collet members 60 that cooperate with the internal profile 42 of the nipple profile means 40. The release mechanism 58 may be attached to a section of blank pipe 62, that in turn will be connected to means for preventing the flow of formation sand 64. In the embodiment shown in Fig. 2B, the preventing means 64 is a section of perforated pipe 66 that is surrounded by a wrapped wire mesh segment 68.

[0021] The bottom hole assembly 30 will also consist of a packer means 70 for sealingly engaging with the well casing 32. The packer means 70 shown is a mechanical packer, however, any type of packer, such as hydraulic or rotational, commercially available from Baker Hughes Incorporated under the product names Model "R", and "SC-LP" packer could be used.

[0022] The assembly 30 will further contain perforating means 72 for perforating the casing 32 in a subterranean reservoir. In the embodiment shown, the perforating means 72 is a tubing conveyed gun; however, any other perforating means well known in the art could have been used. The perforating means 72 will be attached to the packer means 70, and the remainder of the bottom

hole assembly 30 through a mechanical gun release means 74 for mechanically releasing the guns after firing. The release means 74 may be mechanical, or hydraulic automatic gun release means. These release means 74 are also well known in the art, and are commercially available from Baker Hughes Incorporated under the product name Model "C" Auto Release Firing Head. The internal mechanism consists of a piston release means 76 that is hydraulically activated.

[0023] In order to activate the perforating guns, either pressure activation and/or mechanical means can be used. In the preferred embodiment, the mechanical means 77 will be used which is commercially available from Baker Hughes Incorporated and referred to as the Mechanical Firing Head. The actual firing with the mechanical means is performed by dropping a metal bar or bars from the surface.

[0024] Referring now to Figs. 3A-3B, the stationary string 34 and the bottom hole assembly 30 is shown after having fired with the perforating means 72 creating a series of perforating tunnels 77 that extend through the casing and into the formation. Thus, once fired, the pressures created due to the firing of the guns will activate the release means 74, 76. The figure depicts the perforating guns having been fired, lowered, and thereafter having been dropped from the bottom hole assembly 30.

[0025] The illustration of Figs. 4A-4B shows that a secondary string 84, which in the preferred embodiment is a coiled tubing string, is run into the well in the inner diameter 36 of the stationary string 34. The secondary string will have attached to it a crossover tool means 86 for aiding in the placing of a gravel slurry in the annulus area 48 adjacent the perforated casing as is well known in the art and is commercially available from Baker Hughes Incorporated under the product name Model "S-2" Crossover Tool. Also included will be the gravel pack extension means 50.

[0026] The crossover tool means 86 will contain a sliding sleeve member 88 that will shift to the open position by applying pressure in the inner diameter of the secondary string thereby exposing port 90 allowing an operator to gravel pack the perforated zone as is well known in the art.

[0027] Referring first to Figs. 2A & 2B, the method of completing the well may be performed as follows. The stationary string 34 will be in place in the casing 32. The stationary string 34 will be in such a position that the bottom end 35 of the string 34 will be at a point above the reservoir that is to be completed.

[0028] The stationary string 34 will have attached thereto the bottom hole assembly 30 previously described, and the bottom hole assembly will be attached to the stationary string by means of the release mechanism 58, 60. The bottom hole assembly 30 will contain the screen means 64, sump packer means 70 and the perforating means 72, as has been previously described. The location of the bottom hole assembly at this

location, and in particular the perforating means 72, places the assembly in a position to complete the well. In other words, the perforating means 72 in this first position will be adjacent the hydrocarbon reservoir. The perforating guns may be fired by applying internal diameter pressure through the stationary string or annulus pressure or by mechanical means such as dropping a weight bar.

[0029] Next, the perforating guns may be disengaged from the bottom hole assembly by hydraulic means such that the guns fall to the bottom of the well bore, as shown in Figs. 3A-3B.

[0030] Following this, the secondary string 84, which in the embodiment in Figs. 3A-3B and Figs. 4A-4B is a coiled tubing string, is then positioned in the well. It is to be understood that other types of remedial work strings could have been used, such as wire line, electric line, braided line, snubbing pipe, small diameter drill pipe, etc. The coiled tubing 84 will engage in the release mechanism 58, 60 which will detach the bottom hole assembly 30 from the stationary string 34 from the mechanical release 40 and profile 42. The secondary string 84 can then be moved downward and the release mechanism 58, 60 will then be located within the mechanical release profile 54, 56. At this position, the screen means 64 will now be adjacent the perforated reservoir interval.

[0031] The crossover tool 86 as shown is part of the secondary string or it may be run separately such that port 90 will be in a location such that during a gravel pack operation, the gravel slurry will travel down the inner diameter of the coiled tubing 84, and cross over, via the cross-over tool 86, to the annulus 48 through ports 90 and 52.

[0032] Once the gravel slurry has been placed in the appropriate annulus space and perforated zones, the coiled tubing 84 and crossover tool 86 may be disengaged from the release means 58, 60, and the coiled tubing may be removed from the well.

[0033] Referring now to Figs. 5A-5B, a second embodiment of this invention which depicts the drilling and completing method and apparatus will now be described. In Fig. 5B, the bottom hole assembly 100 will be attached to a stationary string 102 as seen in Fig. 5A. The stationary string 102 will contain a packer means 104 for sealingly engaging the casing string 106, or alternatively the open hole 107, so that an upper annulus 108 and lower annulus 110 is formed.

[0034] The stationary string 102 may contain a releasing means 112 for releasably attaching and detaching a secondary string (which will be described in detail hereinafter), with the releasing means containing necessary nipple profiles 114.

[0035] Referring again to Fig. 5B, the bottom hole assembly 100 will consist of bit means 118 for drilling a bore hole, with the bit means depicted being a tri-cone rotating bit; however, it should be understood that other types of bit means, such as Diamond Bits may be employed. The assembly 100 will further consist of a motor

means 120 for effecting rotation to the bit means, which in Fig. 5B is a stator 122 and rotor 124 assembly well known in the art.

[0036] The motor means 120 will in turn be connected to the deflection means 126 for causing a deflection in the bottom hole assembly so that the trajectory of the drilling path is curved. While a deflection means 126 has been shown, the teachings of this invention are certainly applicable to vertical hole completions. The deflection means 126 may be of the type where the angle of deflection is manipulated at the surface and run into the well bore, or alternatively, the deflection means 126, and in particular the angle of deflection, is automatically controllable by transmitting a signal down hole by means of mud pulse, or acoustic telemetry.

[0037] The operator may choose to have a non-rotating swivel means such as a Model "A" Swivel, which is a non-rotating means, in the string; the non-rotating swivel means is not shown and is optional. As seen in Fig. 5B, the deflection means 126 will be attached to a detaching means 134 for releasing the motor means 120 and bit 118 from the assembly 100. In turn, the bottom hole assembly will have attached means for preventing sand production 128, which in the embodiment shown is a sand control means in that there is a segment of perforated pipe 130 that has disposed about it a wire wrapped screen 132. A soluble means, disposed about the sand control means, may be added for preventing the contamination of the sand control means from the drilling fluids and cuttings encountered during the drilling, and completion of the well. The soluble means may also form an impermeable barrier so that fluids can not penetrate through the porous screen 128. The soluble means may be a wax composition; however, other types of compositions are available. The actual soluble means employed will depend on the down hole temperature and the wellbore fluid composition.

[0038] Other types of preventing means can be employed such as a slotted liner well known in the art. The inner diameter of the sand preventing means 128 is denoted as 133. The detaching means 134 for detaching the preventing means 128 from the deflection means 126 and the remainder of the bottom hole assembly 100 is a releasable mechanism means that has contained thereon engaging collets members 136 that is well known in the art that is commercially available from Baker Hughes Incorporated and sold under the product name Mechanical Release Sub.

[0039] As seen in Fig. 5A, there will also be a releasing means 138 for releasing the secondary string from the bottom hole assembly 100. A spacer pipe 139 will connect the screen means 128 and the release mechanism means 138.

[0040] With reference to Figs. 6A-6B, the bottom hole assembly 100 is depicted wherein the bottom hole assembly 100 has connected thereto a secondary string 150, which in this case is a coiled tubing string, and the secondary string is in the process of drilling to a target

reservoir 158. In the embodiment shown, the stationary string 102 is a production tubing string even though other types of conduits could be used such as a stationary drill string. The shifting tool 151, operably connected to the secondary string 150, is used in order to release the drilling bottom hole assembly from engagement with the completion equipment to enable further drilling.

[0041] Thus, for drilling to occur as shown in Figs. 6A-6B, a drilling fluid is pumped down the inner diameter 152 of the coiled tubing 150 and into the motor means 120 thereby effecting rotation of the bit means 118. As can be seen, the coiled tubing 150 is the drilling conduit, and during drilling the fluid flow is out of the bit 118, and into the annulus 108 which includes the cuttings and circulation of the drilling fluids in the open hole section as well as the cased hole section.

[0042] While not depicted in the drawings, it is possible to include in the bottom hole assembly an orienting means, operably associated with the motor, for determining the direction and location of the bit means and generating a signal in response thereto. Also, logging means for evaluating the lithology of a subterranean reservoir and generating a signal in response thereto, and non-rotating means, operably connected on one end to the drill string and on the second end to said motor, for imparting selective rotation to the bit means.

[0043] In order to drill and complete to the target reservoir 158, the procedure first comprises pumping a drilling fluid down the stationary string 102 thereby effecting rotation of the drilling means 118; next, orienting means and logging means will generate a representative signal, and those signals will be transmitted to the surface. The path of the bit means may then be plotted in order to determine the location of the bit. The driller can then steer the bit means in response to the bit location, and ultimately drill through a target reservoir 158 with use of the bit means. The next step is to disengage the drilling assembly, which includes the deflection means 126, motor means 120 and bit means 118. The shifting tool 151 can be utilized to release the drilling bottom hole assembly from engagement with the remainder of the string and the secondary string 150 is removed from the well. The shifting tool is activated by longitudinal movement of the secondary string.

[0044] Referring to Figs. 7A & 7B, a bore hole 107 has been drilled such that the target reservoir 158 has been encountered and the bore hole drilled to a sufficient depth so that the sand prevention means 128 can be lowered to a position adjacent the target reservoir 158. As can be seen, the drilling assembly has already been disengaged utilizing the previously described shifting tool 151. The secondary string 150 has been removed from the wellbore.

[0045] Referring now to Figs. 8A & 8B, the secondary string 150 is again lowered into the well, this time having a cross-over tool means 162 attached thereto. A sliding sleeve member 164 is provided for selective opening on the cross-over tool means 162.

[0046] The crossover tool means 162 will engage the release mechanism means 168 and the bottom hole assembly 100 (which now only contains the sand control means 128) will be connected again to the secondary string 150. The secondary string 150 can be repositioned so that the release mechanism means 168 will now cooperate and engage with the release seat profile 163. At this position, the crossover tool means 162 will also engage with the gravel pack extension 114, and the gravel pack operation may be performed.

[0047] The crossover tool 162, and in particular port 166, will be in a location such that during a gravel pack operation, the gravel slurry will travel down the inner diameter of the coiled tubing, and cross over, via the cross-over tool 162, to the annulus 110 through ports 115 and 166.

[0048] Once the gravel slurry has been placed in the appropriate annulus space and perforated tunnels, the coiled tubing may be disengaged from the release means 168, which is commercially available from Baker Hughes Incorporated under the product name Shifting Tool, and the secondary string may be removed from the well. The well can now be placed on production with the fluids and gas traveling through the gravel pack, into the inner diameter 133 of the bottom hole assembly and then through the inner diameter of the stationary string in order to be produced.

[0049] Changes and modifications in the specifically described embodiments can be carried out without departing from the scope of the invention which is intended to be limited only by the scope of the appended claims.

Claims

1. A method for forming a wellbore, comprising:

a) positioning a stationary string (34) at a desired position within the wellbore, the stationary string (34) having a detachable bottomhole assembly (30) containing

- (i) a perforating device (72) for perforating the wellbore formation,
- (ii) a device (68) for preventing sand from entering from the wellbore into the stationary string (34),
- (iii) a packer (70) for providing a seal between the stationary string (34) and the wellbore formation;

b) activating the perforating device (72) to perforate the wellbore;

c) detaching the bottomhole assembly (30) from the stationary string (34) by a secondary string (84) and attaching it to the secondary string (84);

d) repositioning the bottomhole assembly (30)

so as to place the debris preventing device (68) adjacent the perforations in the wellbore; and
e) sealing a region on either side of the perforations in the wellbore by the packer (70).

2. The method of claim 1, wherein the perforating device (72) is adapted to automatically detach by forces generated upon the activation of the perforating device (72).

3. An apparatus for use in a wellbore, comprising:

a) a stationary string (34,102) positioned in the wellbore, the stationary string having a detachable bottomhole assembly (30,100) disposed at a known location within the wellbore, the bottomhole assembly being adapted to perform an operation downhole; and

b) a secondary string (84,150) adapted to be disposed within the stationary string, said secondary string further adapted to disengage the bottomhole assembly from the stationary string and attach it to the secondary string, said secondary string further adapted to move the bottomhole assembly in the wellbore, down to a second location and to cause the bottomhole assembly to perform the desired operation at the second location,

characterized in that the stationary string (34,102) is adapted to engage the bottomhole assembly (30,100) at at least two spaced locations (40, 54; 114, 163) within the stationary string (102).

4. The apparatus as specified in claim 3, wherein the stationary string includes a production tubing that is attached to an isolation safety device (8) for isolating the wellbore from the outside environment.

5. The apparatus as specified in claim 4, wherein the secondary string (84) includes a perforating device (72) for perforating holes in a wellbore formation.

6. The apparatus as specified in claim 5, wherein the secondary string (84,150) further includes a screen device (64, 128) for preventing entry of debris from the wellbore formation into the stationary string (34, 102).

7. The apparatus as specified in claim 6, wherein the bottom-hole assembly (30) further includes a gravel packer (70) for packing gravel along a region outside the stationary string (34).

8. The apparatus as specified in claim 3, wherein the bottomhole assembly (100) includes a drill bit (118).

9. The apparatus as specified in claim 8, wherein the

bottomhole assembly (100) further includes a motor (120) operatively coupled to the drill bit (118) for rotating the drill bit (118).

10. The apparatus as specified in claim 9, wherein the stationary string (102) is adapted to allow a pressurized fluid to pass therethrough for operating the motor (120). 5
11. The apparatus as specified in claim 10, wherein the bottomhole assembly (100) further includes a measurement-while-drilling device for determining the characteristics of the wellbore formation. 10

Patentansprüche

1. Verfahren zur Bildung eines Bohrlochs, bei welchem 15

a) ein stationärer Strang (34) in einer gewünschten Position in dem Bohrloch angeordnet wird, wobei der stationäre Strang (34) eine loslösbare Bohrlochsohlenanordnung (30) aufweist, die 20

- (i) eine Perforiervorrichtung (72) zum Perforieren der Bohrlochformation, 25
- (ii) eine Vorrichtung (68), die verhindert, dass Sand aus dem Bohrloch in den stationären Strang (34) eintritt, und
- (iii) einen Packer (70) zur Schaffung einer Abdichtung zwischen dem stationären Strang (34) und der Bohrlochformation enthält,

b) die Perforiervorrichtung (72) aktiviert wird, um das Bohrloch zu perforieren,

c) die Bohrlochsohlenanordnung (30) von dem stationären Strang (34) durch einen sekundären Strang (84) losgelöst und an dem sekundären Strang (84) befestigt wird,

d) die Bohrlochsohlenanordnung (30) neu so positioniert wird, dass die das Eintreten von Bergestein verhindernde Vorrichtung (68) angrenzend an die Perforationen im Bohrloch platziert wird, und 45

e) ein Bereich auf jeder Seite der Perforationen in dem Bohrloch durch den Packer (70) abgedichtet wird. 50

2. Verfahren nach Anspruch 1, bei welchem die perforierende Vorrichtung (72) geeignet ist, durch auf die Aktivierung der perforierenden Vorrichtung (72) hin erzeugte Kräfte, sich automatisch zu lösen.

3. Vorrichtung zur Verwendung in einem Bohrloch

a) mit einem stationären Strang (34, 102), der in dem Bohrloch angeordnet ist, wobei der stationäre Strang eine loslösbare Bohrlochsohlenanordnung (30, 100) hat, die an einer bekannten Stelle in dem Bohrloch angeordnet ist, wobei die Bohrlochsohlenanordnung dazu geeignet ist, eine Funktion unten im Bohrloch auszuführen und

b) mit einem sekundären Strang (84, 150), der für ein Anordnen in dem stationären Strang geeignet ist, wobei der zweite Strang ferner zur Lösung des Eingriffs der Bohrlochsohlenanordnung von dem stationären Strang und zu seiner Befestigung am sekundären Strang geeignet ist, der sekundäre Strang weiterhin dazu geeignet ist, die Bohrlochsohlenanordnung in dem Bohrloch nach unten zu einer zweiten Stelle zu bewegen und die Bohrlochsohlenanordnung dazu zu bringen, die gewünschte Funktion an der zweiten Stelle auszuführen, 15

dadurch gekennzeichnet, dass der stationäre Strang (34, 102) für einen Eingriff mit der Bohrlochsohlenanordnung (30, 100) an wenigstens zwei im Abstand voneinander befindlichen Stellen (40, 54; 114, 183) in dem stationären Strang (102) geeignet ist. 20

4. Vorrichtung nach Anspruch 3, bei welcher der stationäre Strang ein Produktionssteigrohr aufweist, das an einer Isoliersicherheitsvorrichtung (8) zum Isolieren des Bohrlochs gegenüber der Außenumgebung befestigt ist. 30

5. Vorrichtung nach Anspruch 4, bei welcher der sekundäre Strang (84) eine perforierende Vorrichtung (72) zum Herstellen von Löchern in einer Bohrlochformation hat. 35

6. Vorrichtung nach Anspruch 5, bei welcher der sekundäre Strang (84, 150) weiterhin eine Siebvorrichtung (64, 128) zur Unterbindung des Eintritts von Bergestein aus der Bohrlochformation in den stationären Strang (34, 102) hat. 40

7. Vorrichtung nach Anspruch 6, bei welcher die Bohrlochsohlenanordnung (30) weiterhin ein Kiespacker (70) zum Packen von Kies längs eines Bereichs außerhalb des stationären Strangs (34) aufweist. 45

8. Vorrichtung nach Anspruch 3, bei welcher die Bohrlochsohlenanordnung (100) einen Bohrkopf (118) aufweist. 50

9. Vorrichtung nach Anspruch 8, bei welcher die Bohrlochsohlenanordnung (100) weiterhin einen Motor (120) aufweist, der funktionsmäßig mit dem Bohrkopf (118) für dessen Rotation gekoppelt ist. 55

10. Vorrichtung nach Anspruch 9, bei welcher der stationäre Strang (102) dazu geeignet ist, ein Druckfluid für die Betätigung des Motors (120) hindurch zu lassen.

5

11. Vorrichtung nach Anspruch 10, bei welcher die Bohrlochsohlenanordnung (100) weiterhin eine während des Bohrens messende Vorrichtung zur Bestimmung der Eigenschaften der Bohrlochformation aufweist.

10

Revendications

1. Méthode pour former un trou de forage, comprenant :

15

a) le positionnement d'un train de tiges fixe (34) à une position désirée à l'intérieur du trou de forage, le train de tiges fixe (34) ayant un ensemble de fond de trou amovible (30) contenant :

20

(i) un dispositif de forage (72) pour forer la formation du trou de forage,

25

(ii) un dispositif (68) pour empêcher que du sable du trou de forage ne pénètre dans le train de tiges fixe (34),

(iii) une garniture d'étanchéité (70) pour réaliser une étanchéité entre le train de tiges fixe (34) et la formation du trou de forage;

30

b) l'activation du dispositif de forage (72) pour forer le trou de forage;

35

c) le détachement de l'ensemble de fond de trou (30) du train de tiges fixe (34) par un deuxième train de tiges (84) et sa fixation au deuxième train de tiges (84);

d) le repositionnement de l'ensemble de fond de trou (30) afin de placer le dispositif de protection contre les débris (68) à proximité des perforations dans le trou de forage; et

40

e) l'étanchéité d'une zone de chaque côté des perforations dans le trou de forage par la garniture d'étanchéité (70).

45

2. Méthode selon la revendication 1, dans laquelle le dispositif de forage (72) est adapté pour se détacher automatiquement sous l'action des forces générées lors de l'activation du dispositif de forage (72).

50

3. Appareil à utiliser dans un trou de forage, comprenant :

a) un train de tiges fixe (34, 102) positionné dans le trou de forage, le train de tiges fixe

55

ayant un ensemble de fond de trou détachable (30, 100) placé à une position connue à l'intérieur du trou de forage, l'ensemble de fond de trou étant adapté pour réaliser un fond de trou d'exploitation; et

b) un deuxième train de tiges (84, 150) adapté pour être placé à l'intérieur du train de tiges fixe, ledit deuxième train de tiges étant en outre adapté pour désengager l'ensemble de fond de trou du train de tiges fixe et le fixer au deuxième train de tiges, ledit deuxième train de tiges étant en outre adapté pour descendre l'ensemble de fond de trou dans le trou de forage jusqu'à une deuxième position et pour faire exécuter par l'ensemble de fond de trou l'opération désirée à la deuxième position, caractérisé en ce que le train de tiges fixe (34, 102) est adapté pour engager l'ensemble de fond de trou (30, 100) à au moins deux positions espacées (40, 54; 114, 163) dans le train de tiges fixe (102).

4. Appareil selon la revendication 3, dans lequel le train de tiges fixe comprend un tubage de production qui est fixé à un dispositif de sécurité d'isolement (8) pour isoler le trou de forage de l'environnement extérieur.

5. Appareil selon la revendication 4, dans lequel le train de tiges secondaire (84) comprend un dispositif de forage (72) pour forer des trous dans une formation du trou de forage.

6. Appareil selon la revendication 5, dans lequel le train de tiges secondaire (84, 150) comprend en outre un dispositif de filtrage (64, 128) pour empêcher l'entrée de débris de la formation du trou de puits dans le train de tiges fixe (34, 102).

7. Appareil selon la revendication 6, dans lequel l'ensemble de fond de trou (30) comprend en outre un filtre à graviers (70) pour accumuler du gravier le long d'une zone à l'extérieur du train de tiges fixe (34).

8. Appareil selon la revendication 3, dans lequel l'ensemble de fond de trou (100) comprend un trépan (118).

9. Appareil selon la revendication 8, dans lequel l'ensemble de fond de trou (100) comprend en outre un moteur (120) couplé de manière opérationnelle au trépan (118) pour faire tourner le trépan (118).

10. Appareil selon la revendication 9, dans lequel le train de tiges fixe (102) est adapté pour permettre le passage d'un fluide sous pression afin d'activer le moteur (120).

11. Appareil selon la revendication 10, dans lequel l'ensemble de fond de trou (100) comprend en outre un dispositif de mesur en cours de forag pour déterminer les caractéristiques de la formation du trou de forage.

5

10

15

20

25

30

35

40

45

50

55

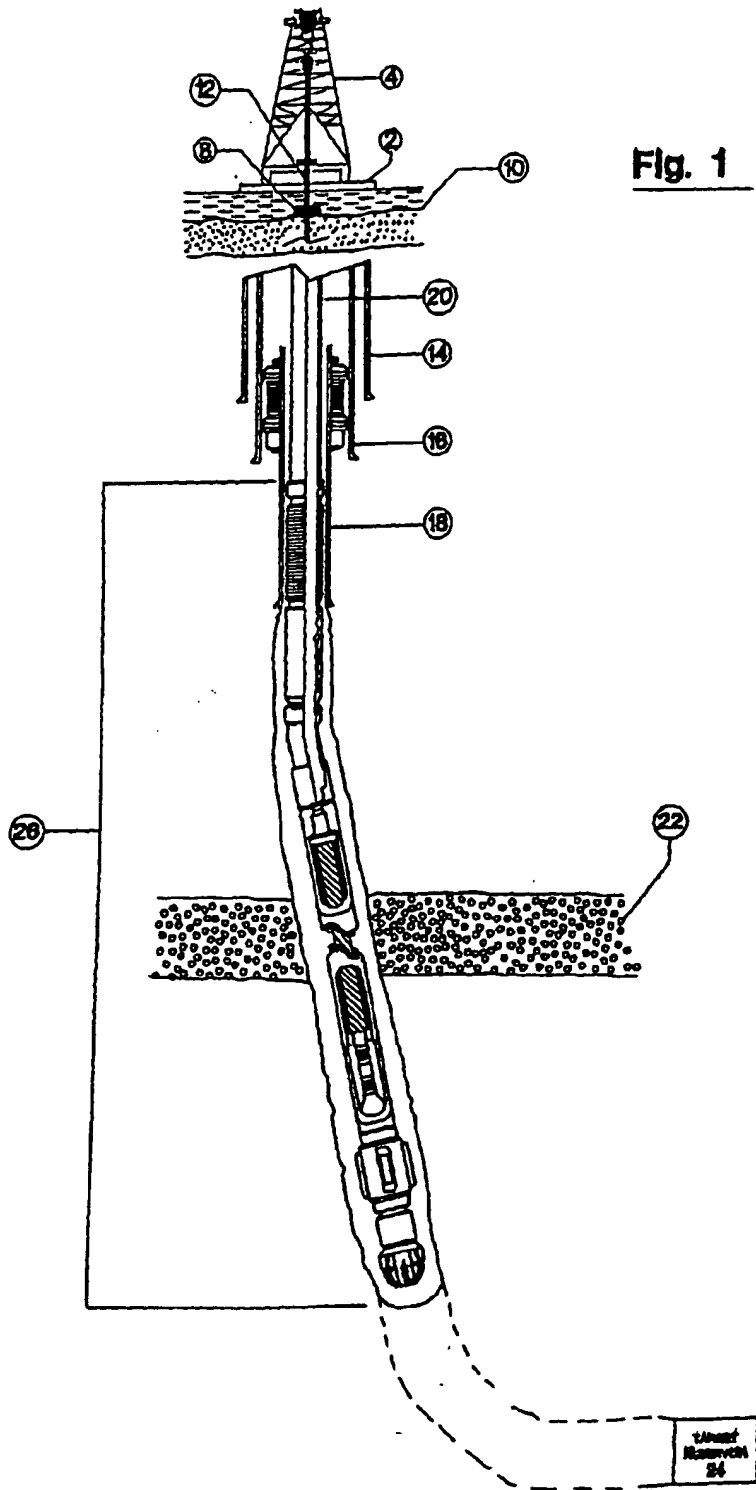

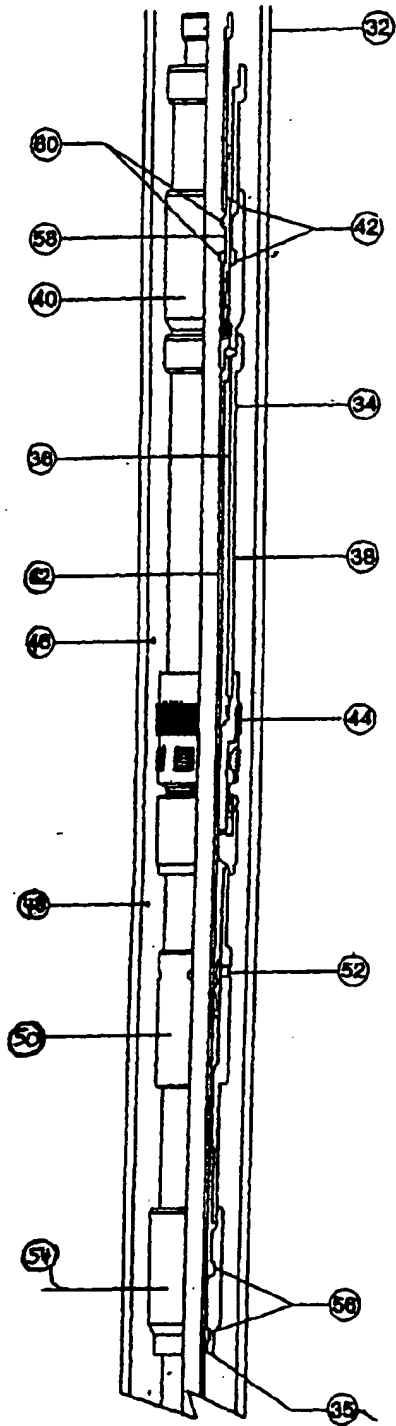

Fig. 2A

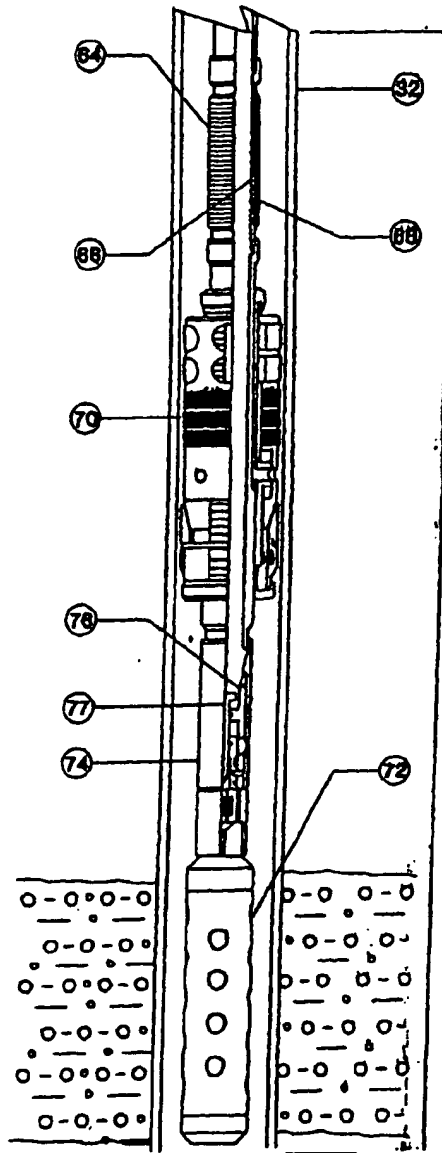

Fig. 2B

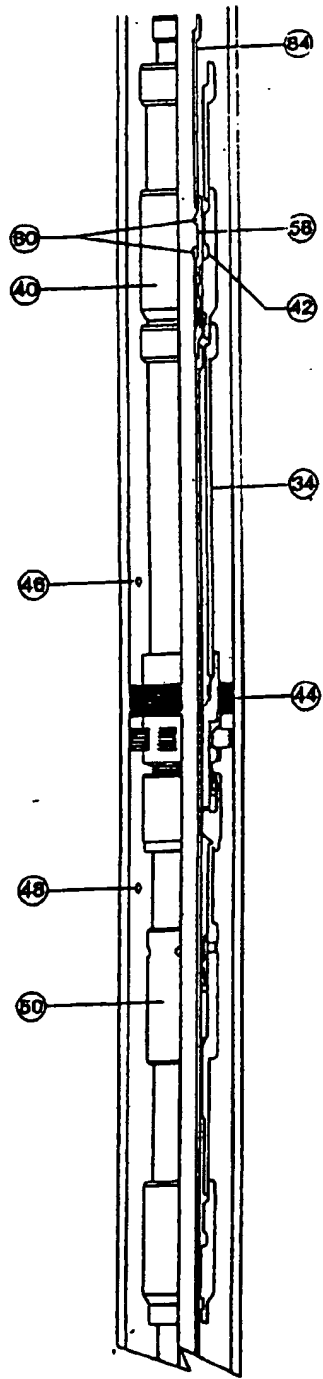

Fig. 3A

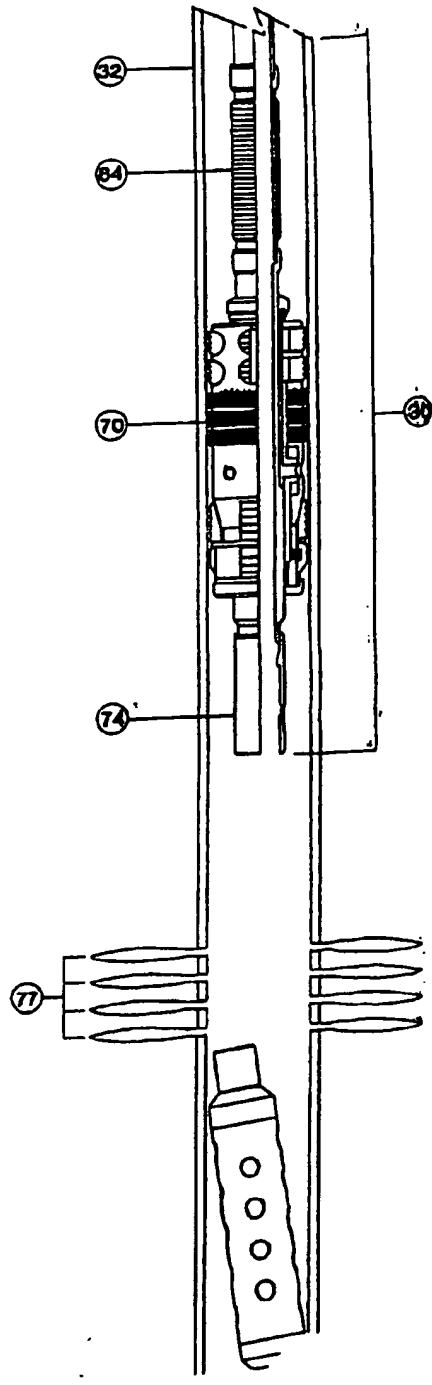

Fig. 3B

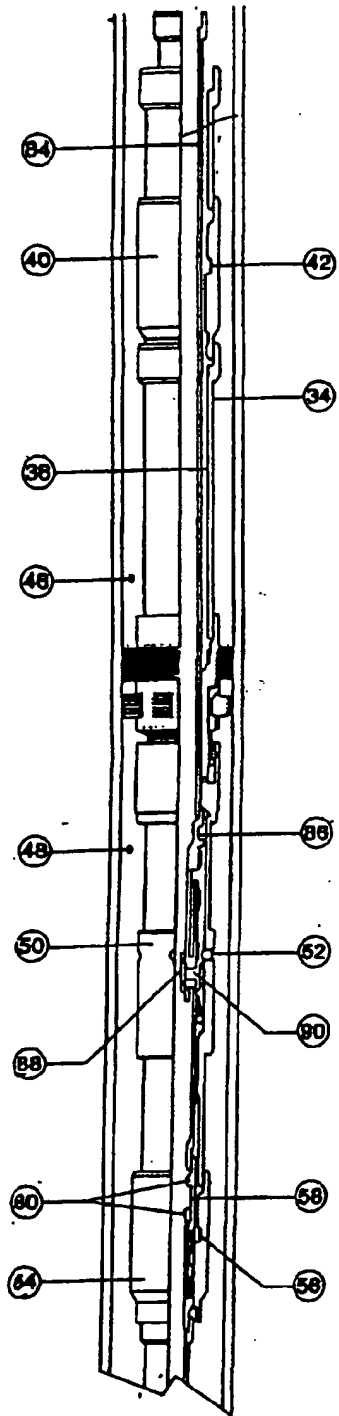

Fig. 4A

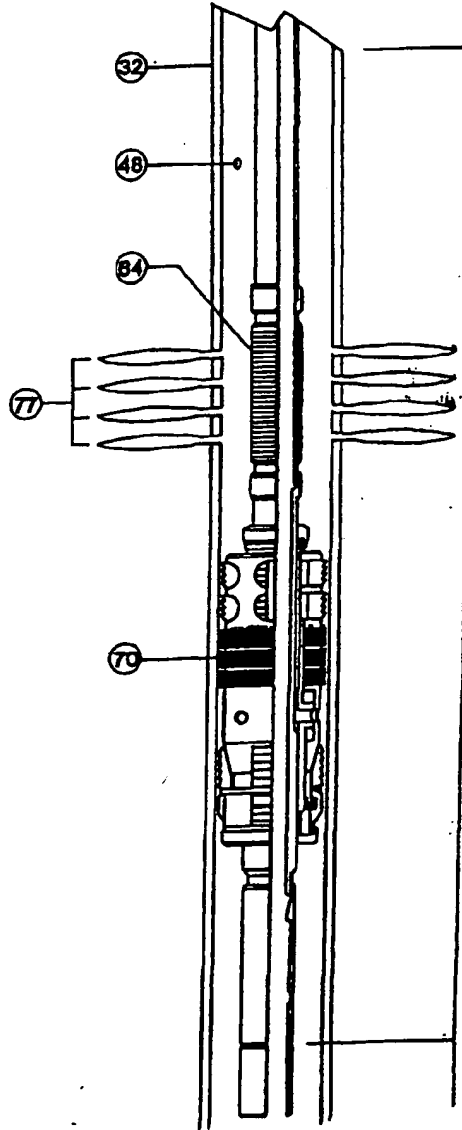

Fig 4B

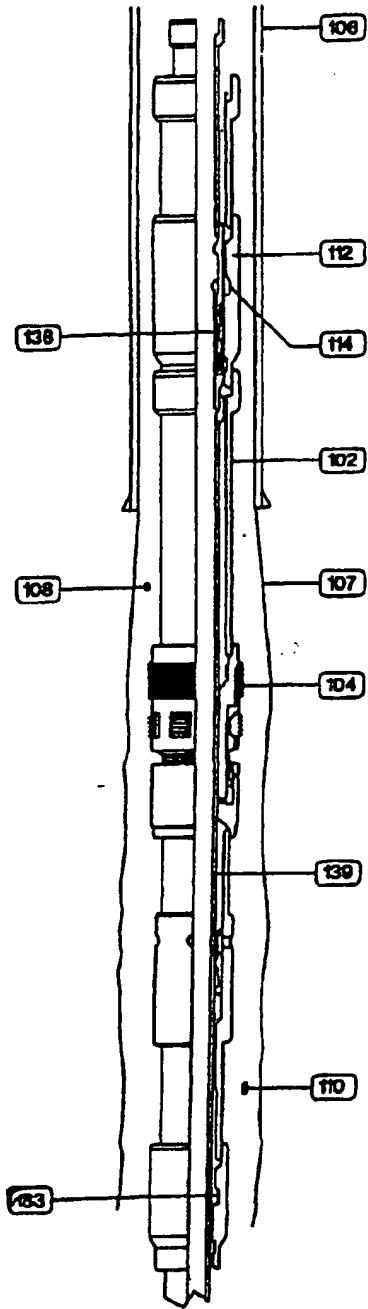

Fig. 5A

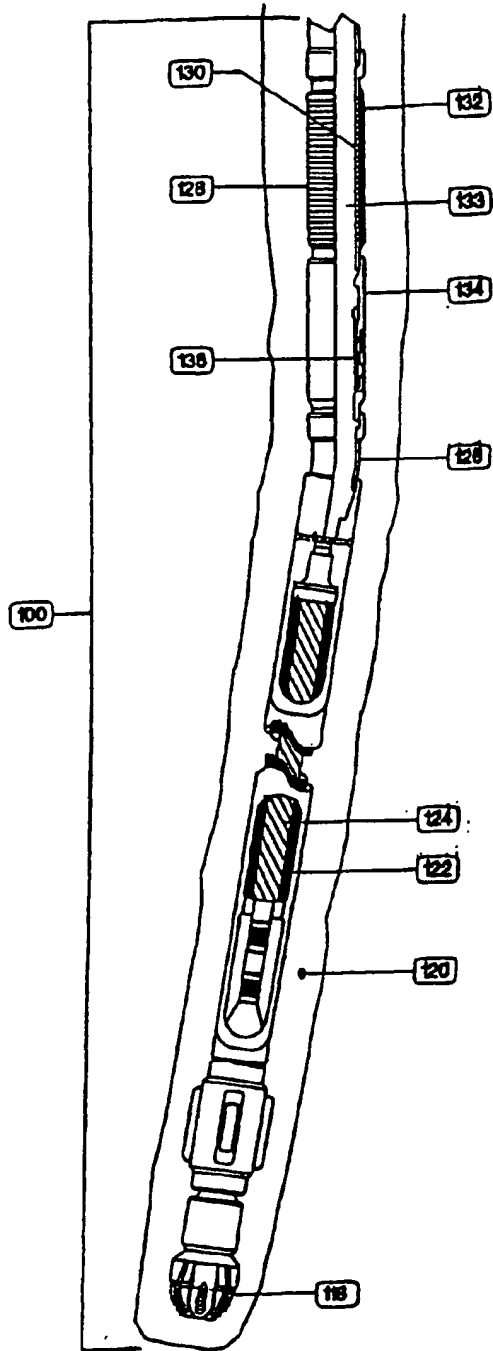

Fig. 5B

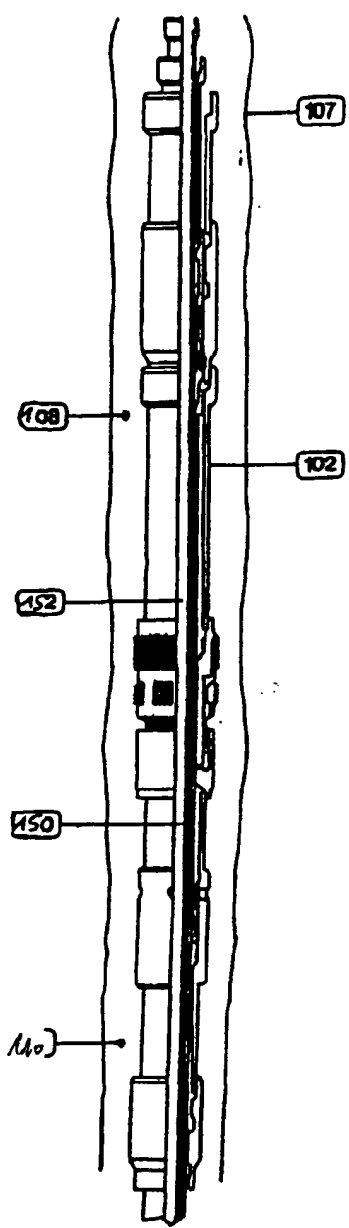
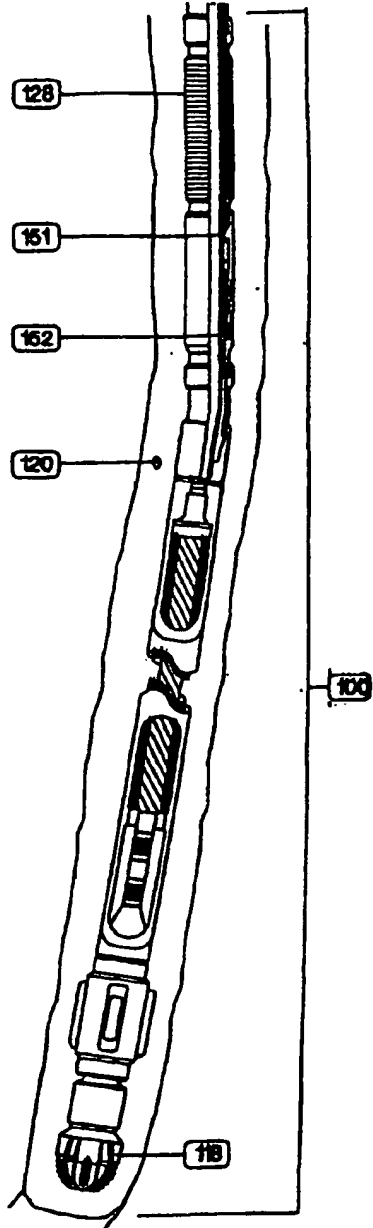

Fig. 6A



Target Reservoir
158

Fig. 6B

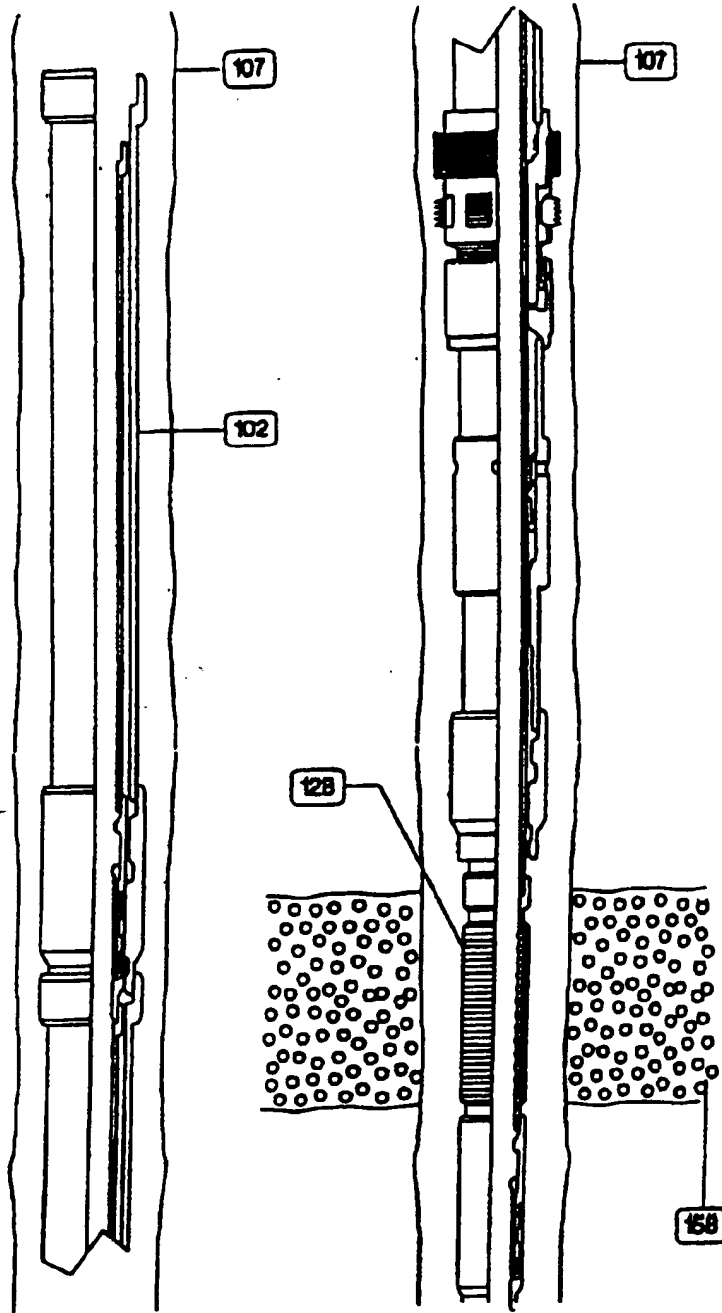

Fig. 7A

Fig. 7B

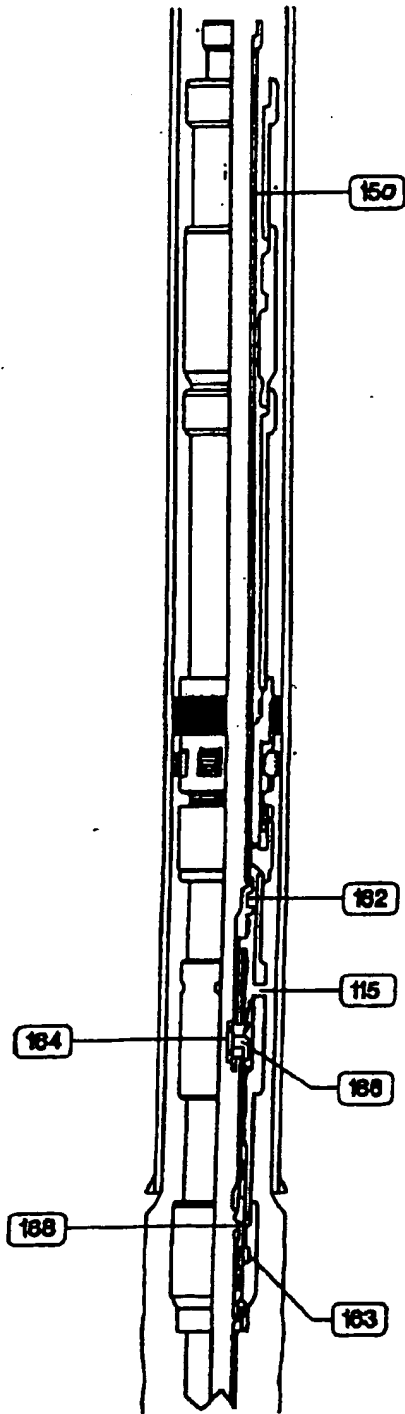

Fig. 8A

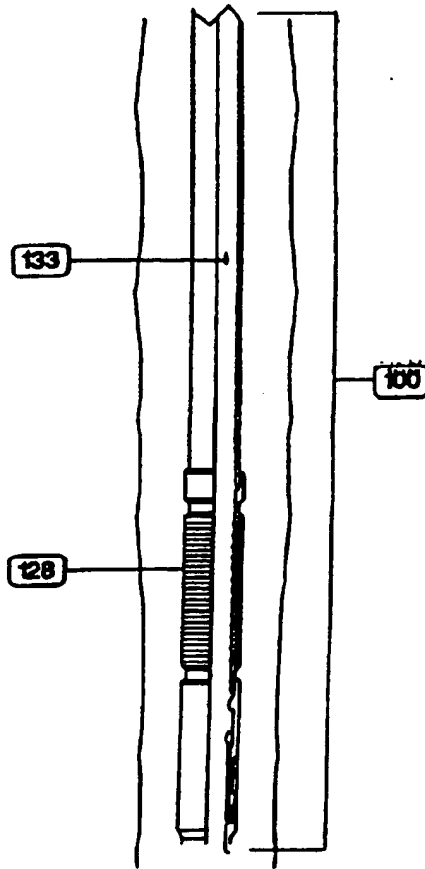

Fig. 8B